

United Kingdom
en

ABSTRACT

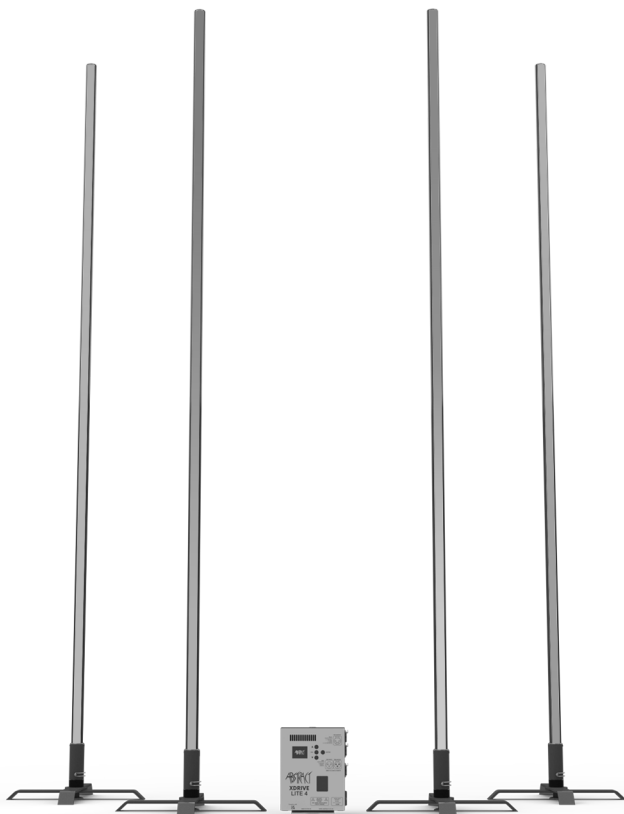

XLite Manual

2m freestanding LED effects pole

ABSTRACT

Disclaimer: Abstract AVR Ltd strongly believes that the information provided in this manual is correct at the time of publishing. However, Abstract AVR Ltd and its affiliated companies are not responsible to any loss, accident, damage or disruption caused by any errors or missinformation within this document. Abstract reserves the rights to revise the content within this manual without any obligation to notify any person or company of such revisions. Abstract has no obligation nor reason to execute any revisions within this document.

Revisions:

<i>Issue No</i>	<i>Date</i>	<i>Notes</i>	<i>Software Firmware</i>
1	01/01/2024	Initial release	V1.0.9
2	18/10/2024	Update	V1.0.27

Updates:

<i>Issue No</i>	<i>Updates</i>
2	New DMX channel modes, added built-in user programs, warm, neutral, cool white options added to standalone mode, sound to light over DMX, WIFI improvements for app ready software.

Usage: This document has been provided for the intended use of providing the latest information on the XLite 4 Pack and its contents. This document has been created for the use of Abstract's customers to print, download and store for future reference and guidance. Please check you have the latest revision of this document by visiting our website: www.abstract.co.uk/manuals

Copyright: The content, illustrations and logos written within this document are solely owned by Abstract AVR Ltd. Abstract restricts the right for any unauthorised person to modify, copy or sell this document. Copyright © 2024 Abstract AVR Ltd. All rights reserved.

ABSTRACT

Introduction: The Abstract XLite is a freestanding 2m LED effects pole with multiple built-in lightshow effects. The XLite sets the bar for lighting excellence, with 140 high performance mix-at-source RGBW LED's, housed in a precision engineered anodised aluminium housing. The lighting enthusiasts freestanding pole of choice. With Abstracts built-in light shows straight out of the box, setting up your lighting effects has never been easier. Programmable via dmx or artnet (with xdrive pro) which allows you to create full pixel mapping shows perfect for all professional stage sets.

Product code: XLITE

Compatible with: XDRIVE LITE 4 & XDRIVE PRO 8/16

Claims

Unpacking: Open the outer packing box taking care not to scratch the product inside when doing so. Handle the contents with care when removing them from the packaging, and check for any damage. If the outer box appears to be damaged or is showing signs of mishandling from shipping, please report to the carrier immediately. Time & dated photos can dramatically help when processing a mishandling claim.

Please recycle any packaging where possible.

Missing items: If you feel you are missing any components or parts that are included within the pack contents, please report directly to Abstract within 7 days of delivery.

Support contacts: Abstract provides a range of support channels to assist you with any problems you may occur when setting up or using your XLite's 4 pack. Some of these channels include:

Landline: +44(0)116 278 8078

Email: support@abstractavr.com

Website: www.abstract.co.uk

Forum: abstract.co.uk/forum

Youtube: Abstract Lighting

Opening hours: 9am - 5pm | Monday - Friday

CONTENTS

Introduction	5
Safety precautions	5
Product overview	6
Product dimensions	7
Spare parts	8
Setup guide	9
Connecting to your stand	9
Wiring diagram	10
Initial startup	11
Standalone mode	11
Menu settings	12
Output settings	12
Standalone	13
Device options	13
DMX configuration	14
DMX setup	14
Setting the DMX address	14
DMX channel modes	15
Master/Slave	15
DMX Charts	16
DMX personalities	17
Wifi network	19
Network settings	19
Connecting to a network	20
App setup	22
Live mode	22
Manual mode	23
Pattern presets	24
Shows	25
Maintenance	27
Specifications	28
Troubleshooting	29
Frequently asked questions	30
Warranty & Returns	31

Warnings: Ensure you read the instruction manual before using.

To prevent or reduce the risk of electrical shock or fire, do not expose this unit to rain or moisture. You must disconnect the unit from the mains by removing the plug from the supply socket BEFORE cleaning or carrying out maintenance and when replacing parts.

Safety notes: These safety notes include important information about the safe operation, installation and maintenance regarding the XLite 4 pack.

DO:

- Connect to mains power supply ensuring an earth is present.
- Store in a dry place, intended for indoor use only.
- Disconnect from power supply when not in use to save component life.
- Replace fuse with same type and rating.
- Always mount this unit in a safe and stable manner.
- Be sure your power supply is suitable for the voltage stated for this unit.
- Mount unit in area supplied with adequate ventilation.
- Be sure to complete all rigging and installation procedures before connecting the main power cord to the appropriate power supply.

DO NOT:

- Expose unit to rain or moisture.
- Spill water or other liquids onto your unit.
- Operate this unit if the power lead is frayed or broken.
- Operate this unit with its cover removed.
- Attempt to operate this unit if it is damaged in any way.
- Look directly at the light source when the unit is on.
- Allow flammable material close to the unit.
- Block any ventilation hole or slots within the unit housing.
- Use outdoors or submerge.
- Allow cables to be walked over, pinched or snagged.
- Open this unit to attempt any repairs.

Cautions:

- If unit malfunctions, stop using immediately and remove power source.
- Unit may get hot when in operation
- Units may fall over if knocked into or snagged.
- Cleaning this unit should be done with care by following the **Cleaning** section of this manual.

XLite x4 Pack includes:

- x4 XLite's
- x4 5m 4-pin XLR leads hard-wired to XLite's
- x4 freestanding base of choice (XStand or Tank Trap)
- x1 XDrive Lite 4 DMX (with built-in wifi)
- x1 IEC mains power lead



Optional Accessories:

- Tank Trap pro base
- 5m XLR 4-pin extension lead
- XDrive Lite 4 truss clamp
- XLite wall-mount clips
- XLite ceiling mount truss clamp
- Carry case

XLite

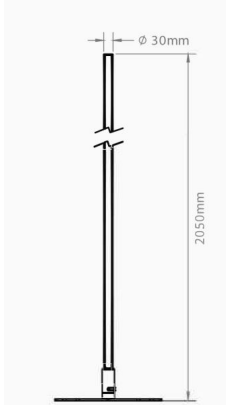

Tank Trap Pro Base *Extra*



XStand

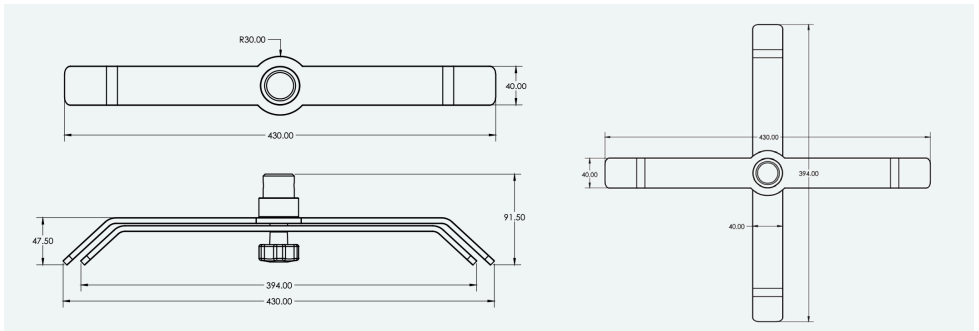

XDrive Lite 4

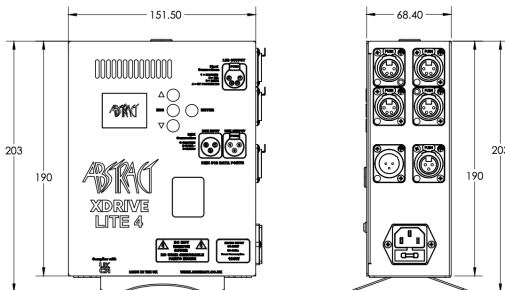

Page left intentionally blank.

Connecting XLite to your stand of choice.

XStand

Step 1: Loosen locking screw and unfold XStand to create study X structure. Lock off screw to tighten

Step 2: Ensure locking pin is removed from XStand. Slot XLite into XStand until pushed fully into the male spigot

Step 3: Ensure holes align and then secure with locking pin

For Tank Trap Pro Base ignore Step 1

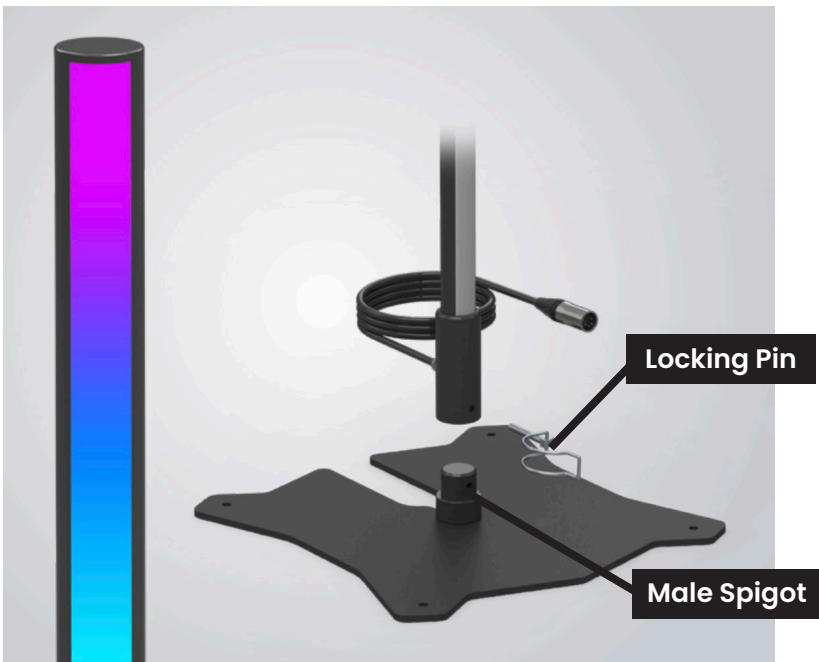



Example Schematic
XDRIVE LITE 4/XLITE PRO

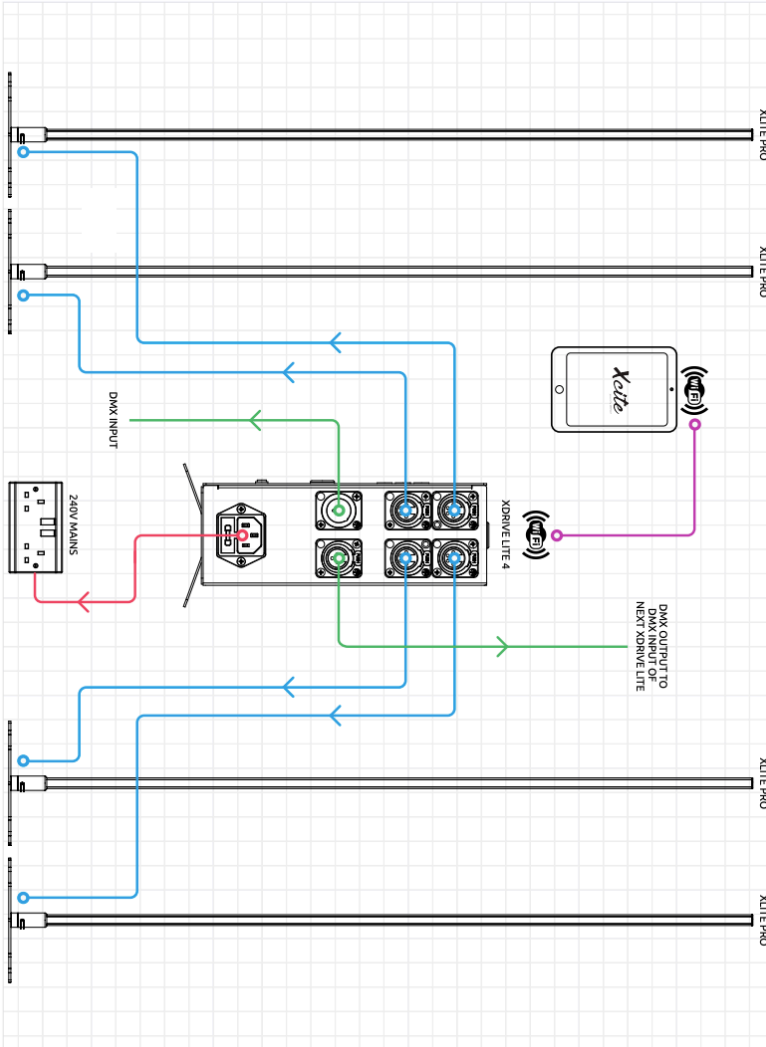

We recommend commencing initial start up without any DMX cables connected to the XDrive to avoid any confusion. For learning how to set up DMX, please see page 14 (DMX Settings).

Once you have wired up your XLite's to the XDrive you are now ready to power up. Plug in your provided IEC mains power lead to the XDrive and the display screen will light up. See *fig 1*

Figure 1

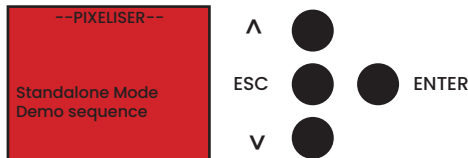

On initial startup you will be presented with an orange backlit background with Standalone mode displayed at the bottom. You are now in Abstracts Standalone mode. In this mode you can scroll through a range of built-in static colours and motion pixel effects.

You can alter how your XLite's communicate to the XDrive, (all same, all seperate, pairs) please see Page 12 (output settings).

To scroll through the presets, simply press the '**enter**' and '**esc**' buttons to navigate through the menu. On User Prog and Sound Prg you can use the '**up and down arrows**' to scroll through 1 - 20 different effects.

Presets Layout - scroll menu using enter & esc

Demo sequence

Red

Yellow

Green

Cyan

Blue

Purple

Warm White

Neutral White

Cool White

User prog 1-30, auto - use up & down arrows to scroll 1-30

Sound prg 1-50, auto - use up & down arrows to scroll 1-50

Stored DMX scene

Rainbow test

ABSTRACT

On initial start up you may need to adjust your output settings to suit your required usage. To do this we will need to go into the Main Menu. To enter the Main Menu, press and hold the **'Enter'** button for at least 3 seconds. See *fig 2*

Figure 2

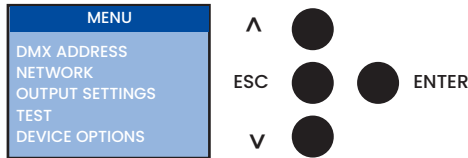

When in the Main Menu, use the **'up and down'** arrows to scroll to **'Output Settings'** and press **'Enter'**. You will now see the output settings sub-menu.

Control mode - allows you set your dmx channel mode (4, 12, 21, 36) or into pixel mode which allows for DMX pixel mapping via third-party software.

LED RGB/RGBW/WW - allows you to set your XLite's to RGB (3 channel), RGBW smartwhite (3 channel), RGBW (4 channel), White (1 channel).
Default set to RGBW.

Number of pixels - sets the number of pixel leds within your light unit. XLite's use 140 led's per tube. *Default set to 140.*

Number of outputs - sets the number of XLite's you want to individually control via DMX. All same, Pairs, All seperate.

Power balancing - allows you to run 4 XLite's from 1 XDrive by using Abstracts power balancing mode. *Default set to On.*

Pixel RGB order - sets the order of how you control your LED's via DMX. *Default set to RGB.*

XDrive has a built-in standalone mode for instant light shows out of the box. You can alter the standalone mode by selecting '**Standalone**' within the Main Menu.

Standalone on/off - allows you to switch standalone mode on and off.

Standalone mode - set the default standalone effect.

User pattern - set the default user pattern.

Sound pattern - set the default sound pattern.

Store DMX scene - captures current dmx input and stores onto Standalone - Stored Scene.

Device options allows you to make changes to your XDrive settings.

Display Mode - Blank after 30 seconds. Show DMX address. Always on.

DMX transmit on/off (Master/Slave) - Sets XDrives to Master/Slave. Set your master driver to DMX Transmit On. And your slave driver to DMX Transmit OFF.

Factory reset - Factory resets your device to the default factory settings.

About - Shows model and firmware versions.

To connect your XLite's to DMX software you will need to connect to the XDrive via a 3pin XLR cable into the DMX input. Once connected, your XDrive will display a green background (DMX mode) and the DMX address as set in the DMX settings. See fig 3 & 4

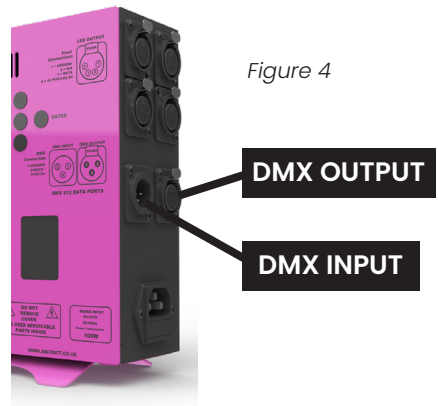
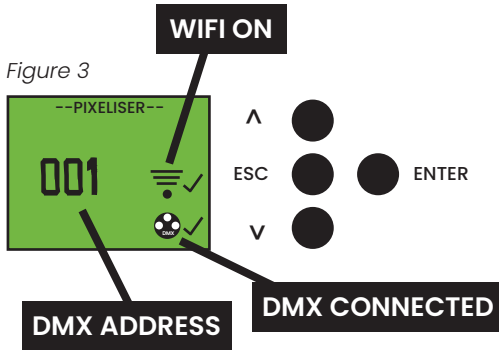

To set your XDrive DMX address, you simply need to enter back into the Main Menu and select '**DMX address**'. You will then be presented with the following options.

- DMX address start - *Default 001*
- Out 1 address - *Default auto*
- Out 2 address - *Default auto*
- Out 3 address - *Default auto*
- Out 4 address - *Default auto*

By selecting DMX address start, it will then allow you to change the DMX address of the XDrive unit. Here you can also set individual DMX address for each XLite pole if required. If left in 'Auto' this will be done for you depending on which channel mode you have selected.

Example if using Auto: Using 6 channel mode, 1st pole will be 001, 2nd pole 007, 3rd pole 013, 4th pole 019. *Set automatically for you*

The XLites come with various channel show modes to aid with programming for a wide range of application.

The following channel modes are available:

4 channel mode (1 Layer)- allows simple 1 pattern select, colour wheel and speed

12 channel mode (3 Layers)- allows pattern select, colour wheel and speed, 3 times - once for each layer

21 channel mode (3 Layers) - allows pattern select, colour wheel, pastel colour, speed, duplicate and soft edge, 3 times - once for each layer

36 channel mode - full programming capabilities available, multiple patterns, RGBW colour mixing, backgrounds, speeds, duplicate, soft edge & length

XLites can be pixel mapped by individual or groups of pixels by going to the '**Output settings**' in the Main Menu and selecting '**Control mode**' > Pix 1, 2, 3, 4 etc...

Overturn to see the personalities for each channel mode.

A digital copy of these is also available at:
www.abstract.co.uk/personalities/xlite

Multiple XDrives can be controlled together by traditional Master/Slave. Link XDrives using a 3 pin DMX cable via DMX input and output connections, and set DMX Transmit options to On for the Master unit. See Menu Settings [page 13].

Pattern Chart

4ch, 12ch, 21ch modes

Value	Setting
000 > 007	Block
008 > 016	Auto
017 > 031	Reverse block
032 > 047	Curtain
048 > 063	Reverse curtain
064 > 079	Comet
080 > 095	Reverse Comet
096 > 111	Bounce
112 > 127	Pulse
128 > 143	Trance
144 > 159	Dissolve
160 > 175	Flame
176 > 191	EQ display
192 > 207	Rain
208 > 223	Expand
224 > 239	Sparkle
240 > 255	Strobe

Reference guide:

Pattern charts see page 16

4 Channel Mode (1 layer only)

Slider	Function	Value	Setting
1	Dimmer	000 > 255	0-100%
2	Colour Select	000 > 255	0-9 White 10-239 Colour Wheel 240-255 Rainbow Slow > Fast
3	Pattern Speed	000 > 255	0-9 Sound to light 10-255 Slow - Fast
4	Pattern Select	000 > 255	See pattern chart

12 Channel Mode (Up to 3 layers)

Slider	Function	Value	Setting
1	L1 Dimmer	000 > 255	0-100%
2	L1 Colour Select	000 > 255	0-9 White 10-239 Colour Wheel 240-255 Rainbow Slow > Fast
3	L1 Pattern Speed	000 > 255	0-9 Sound to light 10-255 Slow - Fast
4	L1 Pattern Select	000 > 255	See pattern chart
5	L2 Dimmer	000 > 255	0-100%
6	L2 Colour Select	000 > 255	0-9 White 10-239 Colour Wheel 240-255 Rainbow Slow > Fast
7	L2 Pattern Speed	000 > 255	0-9 Sound to light 10-255 Slow - Fast
8	L2 Pattern Select	000 > 255	See pattern chart
9	L3 Dimmer	000 > 255	0-100%
10	L3 Colour Select	000 > 255	0-9 White 10-239 Colour Wheel 240-255 Rainbow Slow > Fast
11	L3 Pattern Speed	000 > 255	0-9 Sound to light 10-255 Slow - Fast
12	L3 Pattern Select	000 > 255	See pattern chart

21 Channel Mode (Up to 3 layers)

Slider	Function	Value	Setting
1	L1 Dimmer	000 > 255	0-100%
2	L1 Colour Select	000 > 009	0-9 White
		010 > 239	10-239 Colour Wheel
		240 > 255	240-255 Rainbow Slow > Fast
3	L1 Colour Pastel	000 > 255	0-100%
4	L1 Pattern Speed	000 > 009	0-9 Sound to light
		010 > 255	10-255 Slow - Fast
5	L1 Pattern Select	000 > 255	See pattern chart
6	L1 Duplicate	000 > 255	0-100%
7	L1 Soft Edge	000 > 255	0-100%
8	L2 Dimmer	000 > 255	0-100%
9	L2 Colour Select	000 > 009	0-9 White
		010 > 239	10-239 Colour Wheel
		240 > 255	240-255 Rainbow Slow > Fast
10	L2 Colour Pastel	000 > 255	0-100%
11	L2 Pattern Speed	000 > 009	0-9 Sound to light
		010 > 255	10-255 Slow - Fast
12	L2 Pattern Select	000 > 255	See pattern chart
13	L2 Duplicate	000 > 255	0-100%
14	L2 Soft Edge	000 > 255	0-100%
15	L3 Dimmer	000 > 255	0-100%
16	L3 Colour Select	000 > 009	0-9 White
		010 > 239	10-239 Colour Wheel
		240 > 255	240-255 Rainbow Slow > Fast
17	L3 Colour Pastel	000 > 255	0-100%
18	L3 Pattern Speed	000 > 009	0-9 Sound to light
		010 > 255	10-255 Slow - Fast
19	L3 Pattern Select	000 > 255	See pattern chart
20	L3 Duplicate	000 > 255	0-100%
21	L3 Soft Edge	000 > 255	0-100%

For 32 Channel Mode please see: www.abstract.co.uk/personalities/xlite

The XDrive has its own built-in WIFI hotspot or can join to an existing WIFI network. Once connected the XLites can be controlled and programmed via Abstracts WIFI control software, XCite.

Note: Abstract Device WIFI is only visible for 2 minutes on power up to avoid device latching. If you intend to use your XDrive in WIFI mode please connect to your XDrive within 2 minutes of powering on your device.

Connecting to XDrives built-in WIFI

To connect to your XDrives built-in wifi you need to ensure that WIFI Mode is switched on.

Go to: Main Menu > Network > Wifi Mode > WIFI Self-AP

Important: Once WIFI is switched on you may need to restart your XDrive to activate WIFI mode.

Once you've switched on the built-in WIFI you are now ready to connect. Open your network settings within your smart device (phone, tablet, laptop or computer) and look for 'Abstract-Device-WIFI'. Once connected you will be prompted to enter a 9 digit password for every devices first time connection. Enter the WIFI password '123456789', this is the default factory password. You can change this in the app settings later.

When connected to the Abstract Device WIFI you can now open your internet browser and enter the XDrives IP Address 192.168.4.1
You can now save this a shortcut to your desktop or smart device home screen.

Figure 4

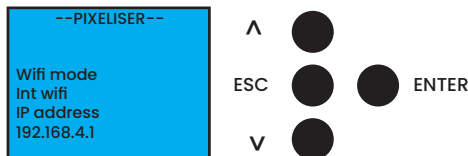

Your XDrive is now setup into WIFI mode and you are ready to start using the online XCite application.

XDrive is able to connect to an external network. To do this you first need to connect to its built-in WIFI hotspot [see page 21] and go to the settings page within the XCite software.

Note: It is important to make sure you restart your XDrive everytime you alter its network settings.

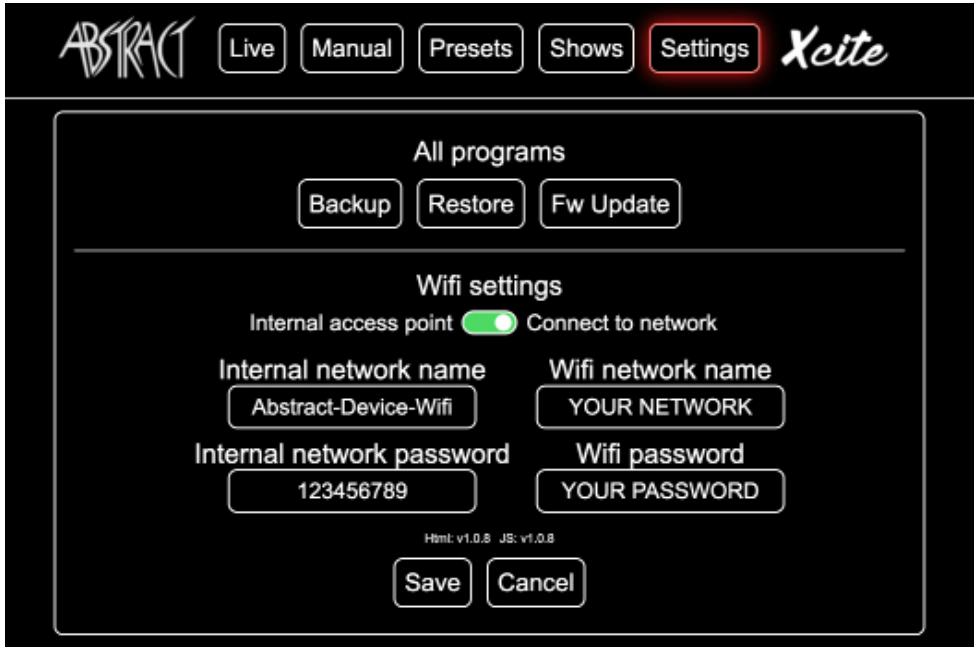

Here you will see the network settings for the XDrive. At this point you can customise your XDrives built-in WIFI name and password to be in keeping with your business.

To enable the XDrive to connect to an external WIFI network you will need to do the following:

XCite settings

- Enter network name into box 'Wifi network name'
- Enter WIFI password into box 'Wifi password'
- Select checkbox icon from 'Internal access point' to 'Connect to network'
- Press save

See next page for XDrive settings

XDrive settings

- Main Menu > Network > Wifi mode > External
- **Restart XDrive unit if it does not auto reboot (IMPORTANT)**
- Check and take note of the new IP address for the XDrive in Main Menu > Network (displayed at bottom of display screen)
- Connect your laptop, computer or smart device to the same network and enter the XDrive ip address into a web browser

You should now see Ext network displayed on the home screen.

Figure 5

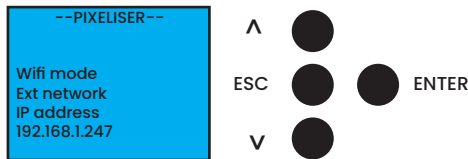

See next page to learn how to use XCite app for programming and live shows.

XCite has a range of modes available to aid in pattern playback and programming. The buttons across the top of the XCite application allow you to select 5 different operating pages. For fixed installations you can limit the pages available to the user by entering the main menu on the XDrive and selecting Network > Web control disable > Select which buttons to disable.

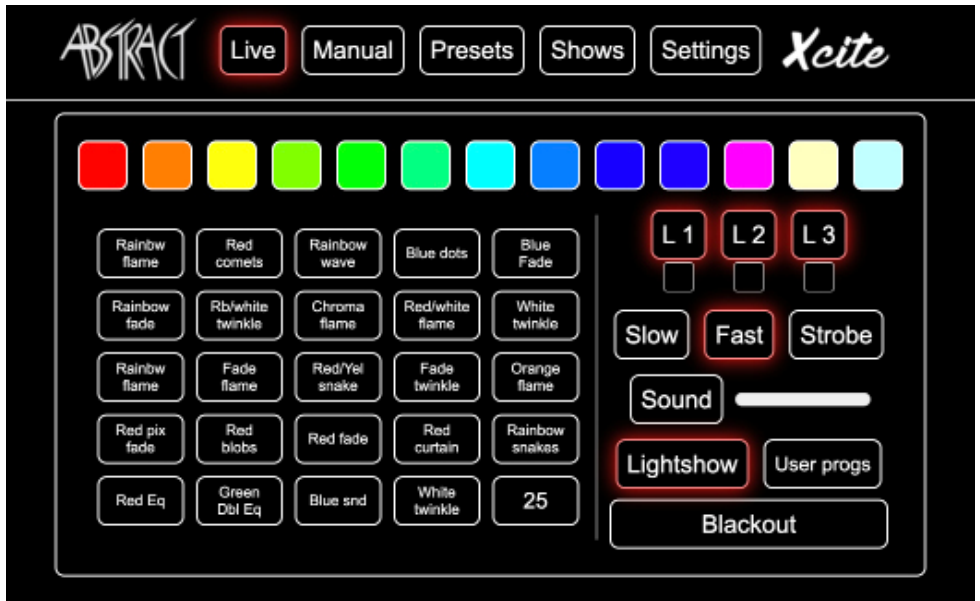

Live Page

This shows the first 25 presets (out of 40) taken from the presets page. These can be edited by visiting the presets page and shuffling the 40 presets around using the Swap button.

In the Live page you also have the ability to override the 25 live presets in various ways.

Lightshow will automatically and randomly scroll through live presets.

User prog is the first lightshow from the Shows page, you can change this label by editing it in the Shows page.

Blackout creates blackouts at the touch of a button

Sound will allow your programs to run sound to light

Slow and Fast controls the speed of the patterns within each preset

L1 L2 L3 allow you to select each layer for each preset, below it are boxes showing each layer with its current selected colour, this can be changed by selecting a colour from the colour pallet.

Manual mode allows you to create your own custom patterns and save them as presets.

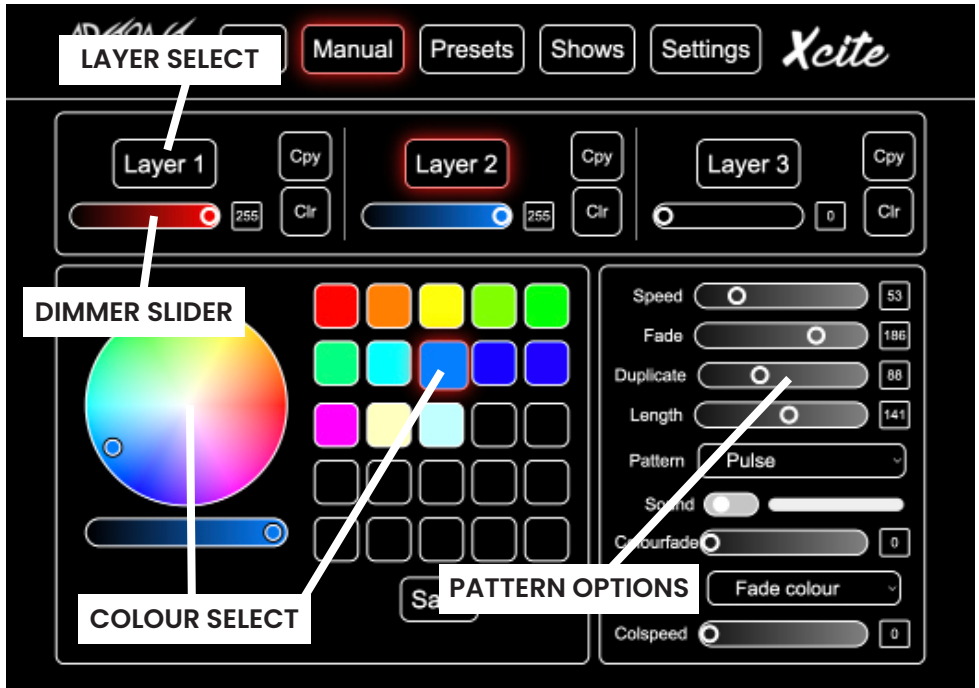

Manual Page

8 steps to creating your own patterns:

1. Select one of the 3 layers
2. Increase dimmer slider
3. Select a pattern from the drop down menu
4. Adjust speed, fade, duplicate and length
5. Select a colour from the colour wheel or pallet.
6. Add sound to light if required
7. Add colour fades and speeds if required
8. Choose next layer and repeat until desired pattern is achieved

Once you have created your pattern you can then save this by going to the presets page and selecting save onto one of the available patterns.

Preset mode allows you to save up to 40 presets.

Note: Live page will show the first 25 presets.



Presets Page

Simple steps to saving your own patterns:

1. Create pattern in manual mode
2. Press save & select an available preset (or override an existing preset)
3. Press label and select the preset you have just saved
4. Rename the preset and press save

As well as saving presets you can also copy, delete, export and import (preset will be saved as a file on your local device)

Remember it is the first 25 presets that will show on the live page.

Shows are a timed sequence of presets. The box on the right shows the time (hh:mm:ss) that each preset will start to run.



Shows Page

To create a show, click edit and then select one of the show buttons. The right-hand display will then change to the Show Edit Screen.

See next page to see how to edit shows.

ABSTRACT

Live

Manual

Presets

Shows

Settings

Xcite

Shows

Edit

Label

Copy

Delete

Show 1 Step 1

00:00:00

Add

Delete

00:00:00 Rainbw flame
 00:00:10 Red comets
 00:00:20 Rainbow wave
 00:00:30 Blue dots
 00:00:40 Blue Fade
 00:00:50 Rainbow fade
 00:01:00 Rb/white twinkle
 00:01:10 Chroma flame
 00:01:20 Red/white flame
 00:01:30 White twinkle

Rainbw flame
 Red comets
 Rainbow wave
 Blue dots
 Blue Fade
 Rainbow fade
 Rb/white twinkle
 Chroma flame
 Red/white flame
 White twinkle

The central box is the current show you have chosen to edit. Highlighted is the selected preset which shows the preset label and start time.

On the left is the current start time for the selected preset which you can now edit (this auto saves). You can now select/highlight further presets within the central box and change their start times.

Note: Presets will be shown in time order, when you edit times the presets may jump around.

You can also select/highlight a preset in the central box and edit the preset with another from the preset selection box on the right-hand side.

You can add or delete steps within the show by selecting/highlighting a preset in the central box and pressing 'add' or 'delete'.

Important: If you want your show to repeat on finish. You MUST add the 'Go To Start' preset at the end. You will find this in the right-hand side preset box.

To exit edit mode, simply press the edit button.

ABSTRACT

Fuse Replacement

Disconnect the XDrive from the power supply and allow 10 seconds for any excess power to fully discharge. Use a flat head screwdriver to remove the fuse holder located directly underneath the power input socket. Remove the fuse and replace with new. Check to ensure the new fuse has the same rating as the factory installed fuse. Secure fuse holder back into housing and re-connect power to test.

Cleaning

Over time your XLite's could form a build up of dirt and dust which may cause long term damage to your units. To avoid this we recommend regular cleaning intervals, increased with heavier usage and more challenging environmental conditions.

The following cleaning method is recommended:

XLite's

1. Unplug your XLites from the XDrive.
2. Wait for 10 seconds for XLites to fully discharge any excess power.
3. Use a vacuum or dry compressed air with a soft brush to remove any excess dirt or dust from the frosted lens and aluminium housing.
4. The frosted lens cover can be cleaned with a mild soap solution, ammonia-free glass cleaner and water.
5. Apply the solution directly to a soft cloth or lens cleaning wipe.
6. Drag any excess dirt the to edges of the frosted lens and collect.
7. Gently wipe off excess solution with a soft cloth until lens is free of marks and smears.
8. Ensure the XLite is completely dry when finished.

XDrive

1. Unplug your XDrive from its power supply.
2. Wait for 10 seconds for the XDrive to fully discharge any excess power.
3. Use a vacuum or dry compressed air with a soft brush to remove any excess dirt or dust from the aluminium housing.
4. The driver housing can be cleaned with a mild soap solution, ammonia-free glass cleaner and water.
5. Apply the solution directly to a soft cloth or lens cleaning wipe.
6. Drag any excess dirt the to edges of the frosted lens and collect.
7. Gently wipe off excess solution with a soft cloth until lens is free of marks and smears.
8. Ensure the XDrive is completely dry when finished.

Specifications

Technical Specifications

Channels

1/6/14/20/36 & Individual Pixel Control

Programming

Instant lightshows via Abstract built-in macros

Control

Via DMX (XDrive Lite 4) or Artnet (XDrive Pro 8/16)

Wattage

30W

Input Current

Constant Voltage 5V

IP Rating

IP20

LED Type

RGBW

Housing

Anodised Aluminium 35mm

Lens Options

160° Frost

LED Connection

4 Pin XLR

DMX Connection

3 pin XLR

Lumen Output

300lm [RGBW]

Operating Temp Range

-10 to 30 °C

Compatible With

XDrive Lite 4 (DMX) & XDrive Pro 8/16 (ARTNET)

Troubleshooting

Below are a list of troubleshooting scenarios with recommended solutions. For further assistance please call our technical support office using the contact details at the back of this manual.

XDrive is not responding to DMX

Check that the DMX cables are connected and wired correctly. Also, check that all cables are connected to the right input and output connections on the XDrive.

XLites are not lighting up but the XDrive display screen is on

Ensure that the XLites are plugged into the dedicated 4 pin XLR outputs and that the cables are not damaged. The Output settings may not be set correctly. See 'output settings' [page 12] to ensure you have set the settings correctly. If you are connected to DMX you will need a DMX controller to program the lights and a correctly set DMX address. See 'DMX setup' [page 14].

The XLites are not responding correctly to the WIFI app

For the WIFI modes to respond correctly you need to ensure you have turned off standalone mode. To do this you need to enter the main menu > standalone > standalone on/off > off. The home screen should now be backlit in blue (WIFI mode) showing the XDrives IP address.

The XLites are not responding to sound

If using standalone mode, ensure you have selected a 'Sound prg' and not 'User prg'. If using DMX ensure you have the speed slider to full 255 to activate sound to light, see DMX personalities [page 17]. If none of these solutions work you may need to send your XDrive in for a mic repair, see our warranty and returns section [page 24].

Frequently Asked Questions

Below you will find answers to the most common questions you may have on the XLITE PRO. Also please feel free to Contact Us if you still can't find what you are looking for.

How do I power my XLITE PRO up?

To power the XLite's you will need an XDrive Lite 4. This will power up to 4 XLite's (1 on each individual output).

How do I control my XLITE PRO?

Using the XDrive you can utilize the XCite software pre-built into the LED Driver. This allows you to control your XLite's using your phone/tablet/computer via Wifi.

Can I use my XLITE PRO outside?

No, the XLite is not suitable for outdoor lighting. Unless it is under a suitable cover to protect it.

Does the XLITE PRO work with sound to light?

Yes, the XLite is our most receptive light unit with sound to light that Abstract has ever manufactured.

How many XLITE PRO's can I run?

There is no limit. To run more XLite you can daisy chain your XDrive XLite's via the "DMX Input/Output".

What is standalone mode?

Standalone mode allows you to control multiple XLite's individually from the same XDrive.

Can each XLITE do different patterns in stand alone mode?

Yes they can. The XDrive has a selection of pre-set patterns that allow each XLite to have it's own individual pattern simultaneously.

Warranty and returns

Warranty

The XLite carries a 2 year structured warranty from date of purchase. As standard an automatic 1 year back to base warranty is applied from factory. You will need to register your Abstract products online to receive a further 1 year parts and labour warranty by visiting www.abstract.co.uk/warranty. See the warranty card within your box for more detailed instructions on how to register.

Returns

When returning units whether under warranty or not, it must be accompanied with an Abstract unique returns number, please contact Abstract AVR Ltd customer support for a URN number. **Do not** send your product to us if you have not yet secured a URN number. If the unit is under warranty, you must provide a copy of your proof of purchase invoice and send via email or place inside the returns box. Abstract AVR Ltd is not responsible for delays in repairs or shipping.

Products not under warranty

When obtaining your URN number, please notify customer services that your product is no longer within warranty. You will then be contacted by Abstract with a quotation for the repair including shipping charges. All authorised Abstract repairs will be complete with a 90 day labour and material repairs warranty starting from the date of shipping.

Shipping

When shipping units back to Abstract, products must be adequately packed and insured by you. Any damage during return shipment, whether due to inadequate packing or carrier mishandling is your sole responsibility. Double-box all returns and surround it with suitable packing materials, such as bubblewrap, foam inserts and styrofoam balls.

Repair Tracking

Once we have received your returns you will receive a link via email to our online repairs tracking system, where you can check for regular updates on the repair work and its status.



**LED THE GOOD
TIMES ROLL**

Contact Us

Abstract AVR Ltd
Westfield Rear of 24/26,
Leicester Road,
Blaby, LE17 4GQ
United Kingdom

+44(0)116 278 8078
sales@abstractavr.com
www.abstract.co.uk