

**TECHNICAL SPECIFICATIONS**

- Voltage **24V**
- LED Outputs **4**
- Output Current **5A**
- Power Consumption **320W**
- Channels **1-16Ch (RGB[W]x4)**
- Power Input Mains **110-240VAC**
- Data Connections **3 Pin XLR / RJ45**
- LED Connection **5 Pin Pheonix Connector**
- Operating Temp Range **-20° to 50°C**

**DIMENSIONS**

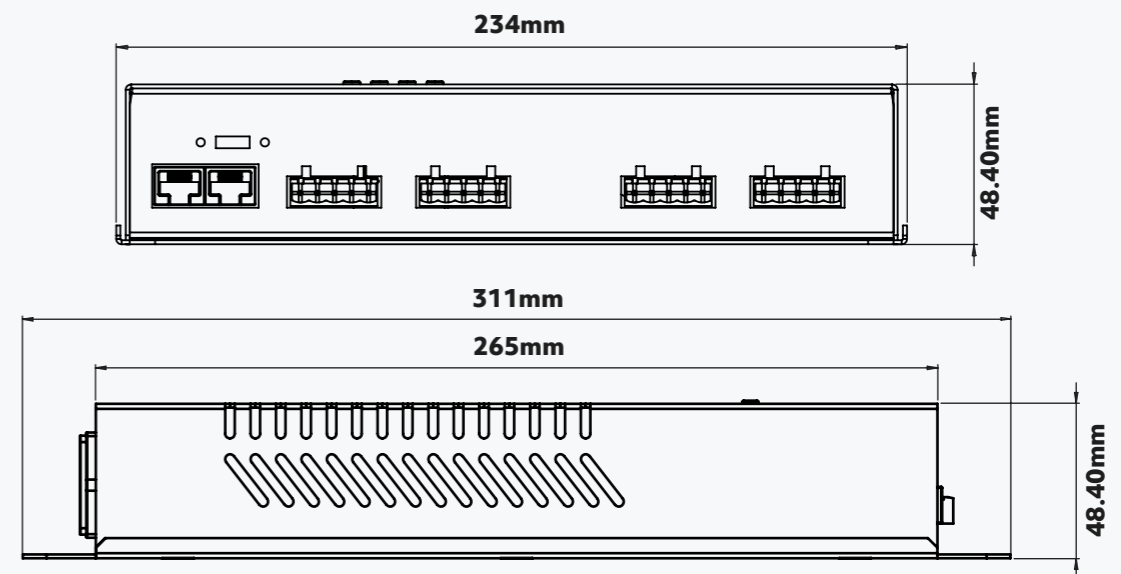

**CONNECTIONS**

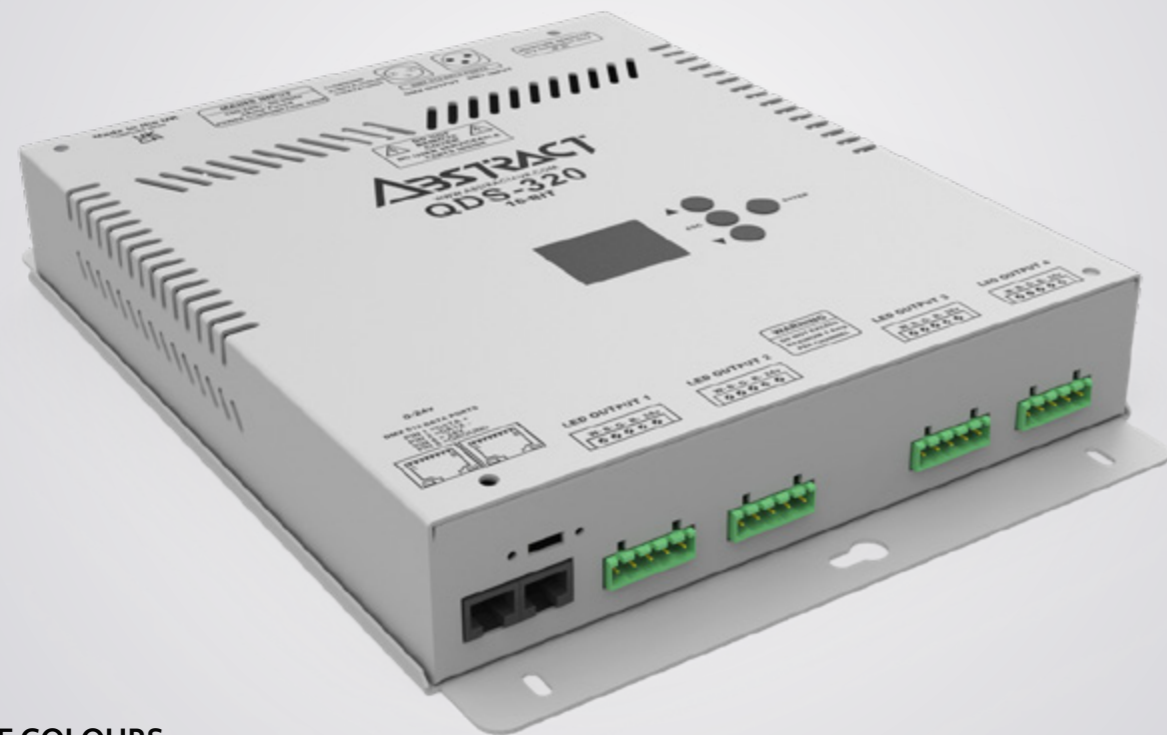
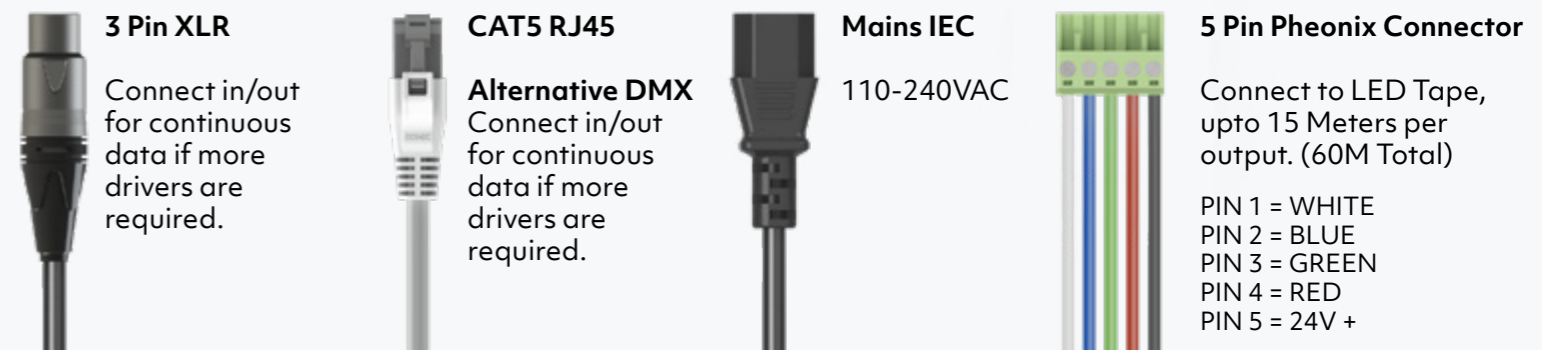

**AVAILABLE COLOURS**



# QUAD DRIVE S 320

## CV LED DMX DRIVER

**Designed to work with 60 LED per meter RGB/W SMD5050 LED**

Make medium sized installations simple. With up to four zones of control and up to 60M of colour change LED strip all powered from one intelligent box.

A premium quality product, with super smooth 16bit dimming and unrivalled RGB + tuneable white control, this is the most advanced DMX driver technology on the market.

**Product Code: QDS-320**