



AVAILABLE COLOURS



QUAD DRIVE S 150

CV LED DMX DRIVER

Designed to work with 60 LED per meter RGB/W SMD5050 LED

With twice the power of its predecessor, start to take on multiple rooms of colour change LED strip from a single driver unit, driving up to 30 meters across up to two controllable zones.

Experience lighting at its best with super smooth 16bit dimming and RGB + tuneable white control, from the most advanced DMX driver technology on the market.

Product Code: QDS-150



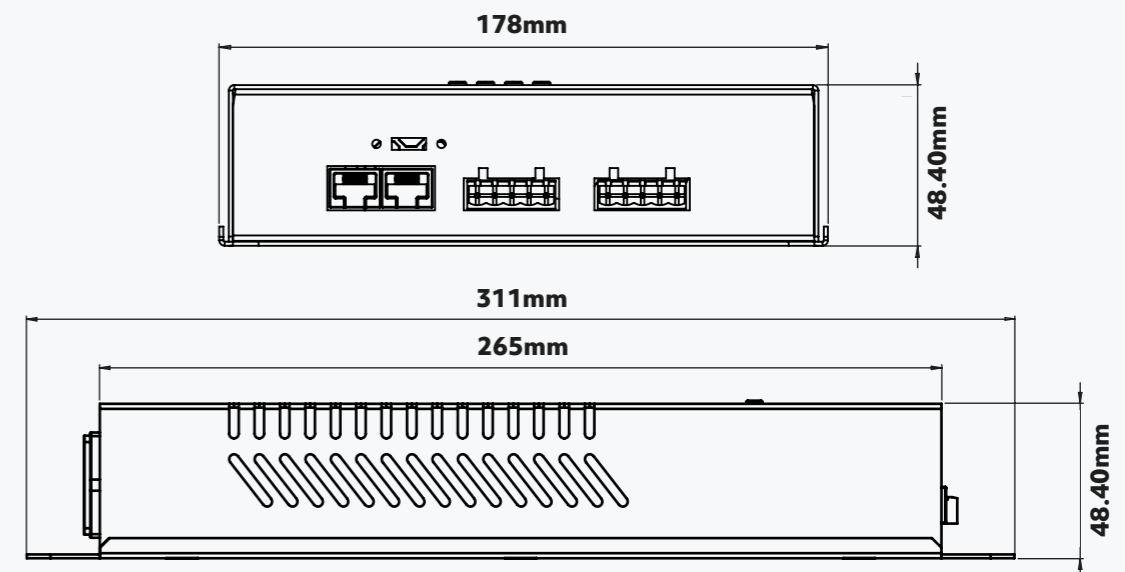

TECHNICAL SPECIFICATIONS

- Voltage **24V**
- LED Outputs **2**
- Output Current **5A**
- Power Consumption **150W**
- Channels **1-8Ch (RGB[W]x2)**
- Power Input Mains **110-240VAC**
- Data Connections **3 Pin XLR / RJ45**
- LED Connection **5 Pin Phoenix Connector**
- Operating Temp Range **-20° to 50°C**

DIMENSIONS



CONNECTIONS

 <p>3 Pin XLR Connect in/out for continuous data if more drivers are required.</p>	 <p>CAT5 RJ45 Alternative DMX Connect in/out for continuous data if more drivers are required.</p>	 <p>Mains IEC 110-240VAC</p>	 <p>5 Pin Phoenix Connector Connect to LED Tape, upto 15 Meters per output. (30M Total) PIN 1 = WHITE PIN 2 = BLUE PIN 3 = GREEN PIN 4 = RED PIN 5 = 24V +</p>
--	---	--	---